

Fit™ Mobile Cart

FOR INTERACTIVE DISPLAYS

This mobile AV cart fits flat panel displays:

- 55" to 86"
- Up to 175 lbs. (79 kg)
- Up to 800 x 600 VESA

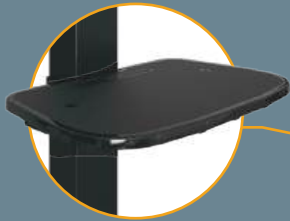

Height-adjustable shelf is included to store accessories like keyboards, laptops, and styluses.

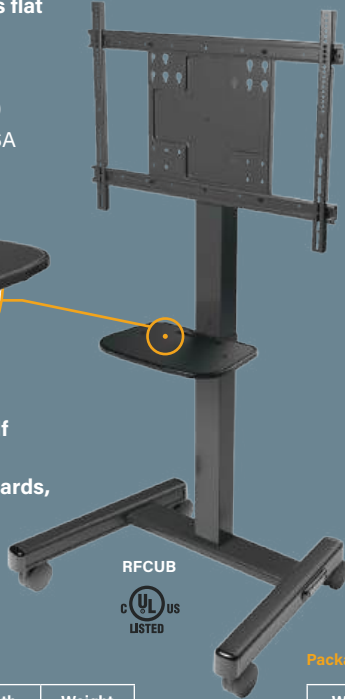

Three adjustable height locations from 44" (112 cm) to 60" (153 cm) accommodates accessibility for a wide range of users.

- Easy to set prior to display installation

Fit Mobile Cart is developed to maintain stability while users interact with touchscreen TVs.

- Robust 4" casters
- Compact 29" legs enhance safety and maneuverability
- Built for efficiency, speed and easy movement



Product Measurements

Width	Height	Depth	Weight
36.2" (920mm)	72.3" (1836mm)	29.1" (739mm)	65.3 lbs (29.6 kg)

Package Measurements

Width	Height	Depth	Weight
38.3" (972mm)	7.2" (182mm)	20.2" (512mm)	74.0 lbs (33.6 kg)



Accommodates TVs, including interactive displays, from 55" to 86" and up to 175 lbs. (79 kg)



For displays with 400x400 VESA or smaller, mount directly to the face plate.

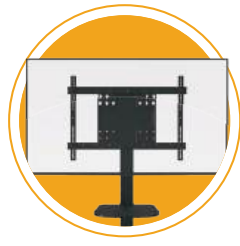

For displays with larger than 400x400 VESA, use the included interface brackets before attaching to the face plate.

CHIEF[®]
A brand of **Legrand**

Fit™ Mobile Cart

THE RIGHT FIT FOR INTERACTIVE DISPLAYS

The **Fit™ Mobile Cart** for Interactive Displays is designed for flexibility. Move TVs for optimal viewing and collaboration for corporate, education and many other spaces!

Product Features:

- Typical Screen Sizes: 55" to 86"
- Display Mounting Pattern: Up to 800 x 600 mm
- Display Weight Capacity: 175lbs (79kg)
- Shelf Weight Capacity: 10lbs
- Display Height Positions
(Center of Display): 44", 52" or 60"
- Certifications: UL Listed



Fit™ Mobile Cart

FOR INTERACTIVE DISPLAYS

Technical Drawing

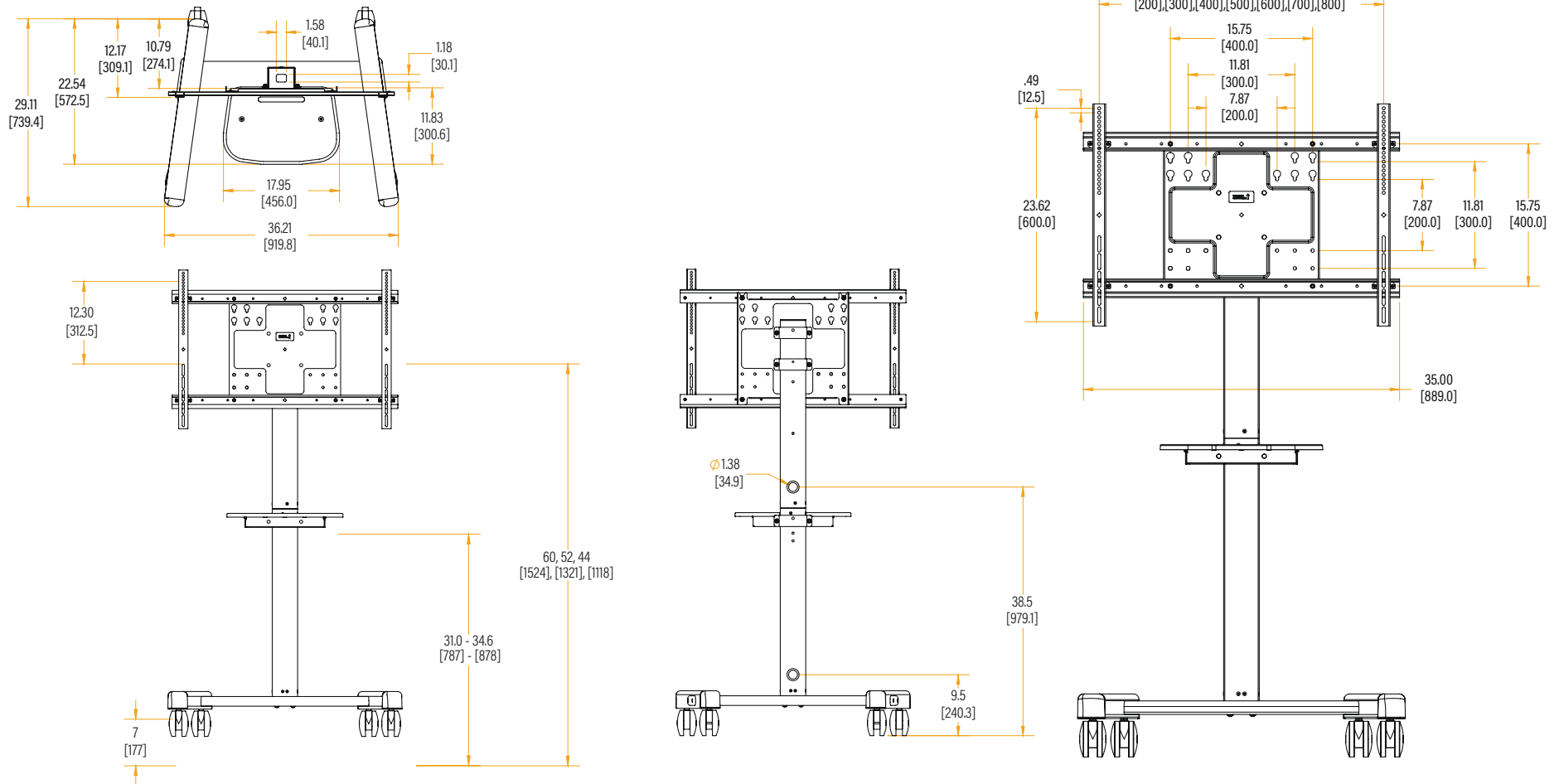

INSTALLER INSPIRED | legrandav.com

USA 866.977.3901 av.chief.support@legrand.com CANADA 877.345.4329 av.chief.canada@legrand.com

EMEA +31 495 580 840 av.emea.sales@legrand.com APAC +852 2145 4099 av.asia.sales@legrand.com

LEGRAND | AV COMMERCIAL BRANDS

C2G | Chief | Da-Lite | Luxul | Middle Atlantic | Vaddio | Wiremold

**PICK UP
THE PACE
WITH
TEMPO**



TEMPO[™] FLAT PANEL
WALL MOUNT SYSTEM

TEMPO™ FLAT PANEL WALL MOUNT SYSTEM

This all-in-one configurable wall mounting system is designed to improve efficiency by streamlining installation workflow. AV professionals can increase productivity and add money to the bottom line with this new system, especially for mass rollouts.

Install on any wall and neatly store AV devices with simple, unparalleled service access. Install up to six small devices behind the display on integrated Lever Lock™ storage panels. Tempo Wall Mount System is thoughtfully designed with feedback from installers for faster deployments.

Accelerate AV Installations

- One part number, one box, one order!
- Ship to site pre-loaded with small devices and cabling.

Save Money

- Reduce onsite installation personnel and time.
- Minimize last-minute shipping costs of missing parts.

Feature Flexibility

- Wall plate and sliding interface design facilitates centering display in the right position.
- 10° of adjustable display tilt in 2.5° increments.

Streamlined for Success

- Total installation depth facilitates ADA compliance.*
- Up to 1" (25 mm) post-install leveling adjustment.

*When display depth is less than 2" (51 mm)

Integrated Storage

- Ships with two 15"x10" Lever Lock™ plates with space to add more.
- Storage plates can be moved along the mounting rail for best placement of components.
- Includes six cable management clips to keep cables tidy for a professional-looking installation (**NEW** in October 2024).

Simplify Service

- Approximately 13" (330 mm) of service access.
- Open wall plate for easy positioning of power and data sources and in-wall storage.
- Home latch lockout clip prevents home latch from accidentally locking until pull cords are properly stowed (**NEW** in October 2024).

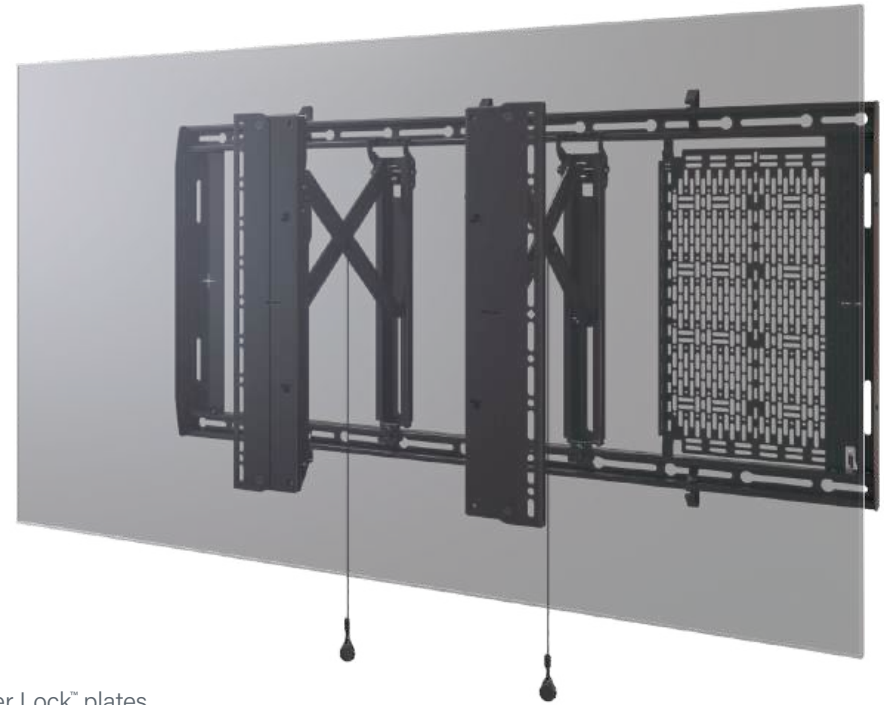

TEMPO™ SPECIFICATIONS

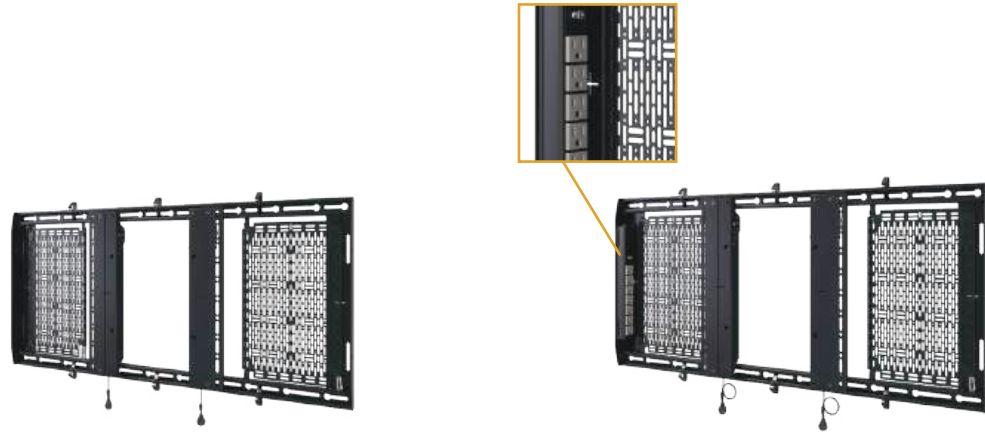

Part Number	AS3LD	AS3LDP7
Name	Tempo™ Flat Panel Wall Mount System	Tempo™ Flat Panel Wall Mount System with PDU
Power Distribution Unit	None	Middle Atlantic Slim Profile Power Strip (7 outlet, 15A, 3ft/0.9m cord with right-angle plug)
Typical Display Size	49"-86"	
Display Weight Capacity	200 lbs (90.7 kg)	
Display Mounting Pattern	Up to 970 x 450 mm	
Dimensions (W x H x D)	42.03" x 19.75" x 1.96" (1068 x 502 x 50 mm)	
Wall Substrates	Steel stud, wood stud, concrete, and block walls	
Post-Install Leveling	1" (25 mm)	
Lateral Shift	Yes	
Tilt	-10°/+0°, 2.5° increments	
Plumb Adjust	0.38" (10 mm)	
Storage Dimensions (W x H)	Includes (2) 10" x 15" (250 x 402 mm) Lever Lock plates	
Storage Weight Capacity	20 lbs (9 kg) per Lever Lock plate	
Service Extension	10.65" (271 mm)	
Service Depth	12.61" (320 mm)	
Color	Black	
Certifications	UL	PD-715SC-NS; ETL

TEMPO™ FLAT PANEL WALL MOUNT SYSTEM

PURPOSEFULLY DESIGNED with 42" x 19.75" (1068 x 502mm) footprint - hides behind typical 49" displays and larger

* **UL LISTED** and **TUV CERTIFIED** (pending)
Safety tested for installation on metal or wood studs, concrete or block wall substrates

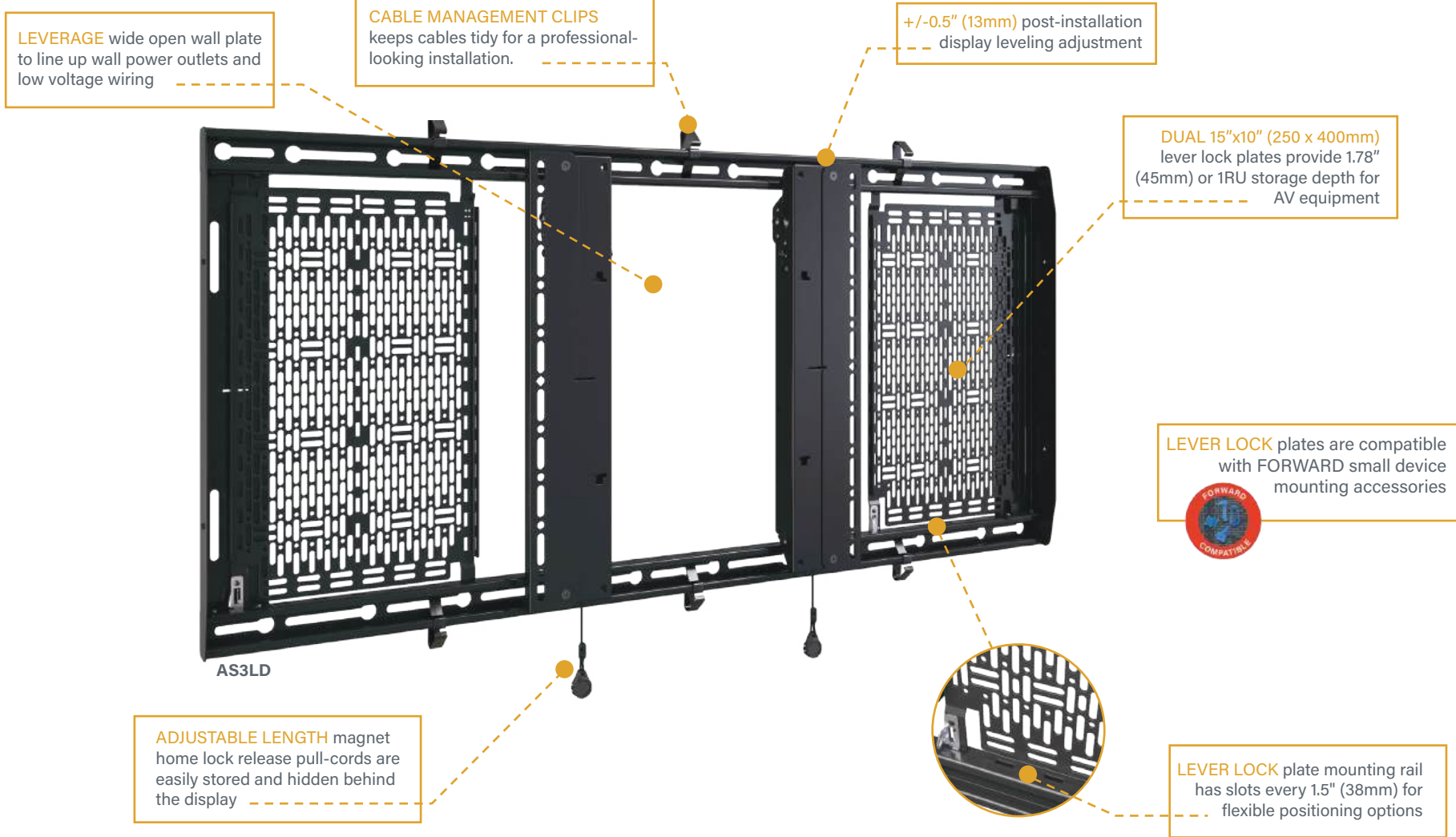

LEVERAGE wide open wall plate to line up wall power outlets and low voltage wiring

CABLE MANAGEMENT CLIPS keeps cables tidy for a professional-looking installation.

+/-0.5" (13mm) post-installation display leveling adjustment

DUAL 15"x10" (250 x 400mm) lever lock plates provide 1.78" (45mm) or 1RU storage depth for AV equipment

LEVER LOCK plates are compatible with FORWARD small device mounting accessories



ADJUSTABLE LENGTH magnet home lock release pull-cords are easily stored and hidden behind the display

LEVER LOCK plate mounting rail has slots every 1.5" (38mm) for flexible positioning options

TEMPO™ FLAT PANEL WALL MOUNT SYSTEM WITH PDU



★ SLIM 15A 7-outlet PDU ships with AS3LDP7 to power full AV system. Includes 3ft (0.3m) cord and 90° plug-in for a better installation experience (**NEW** Nov. 2024)

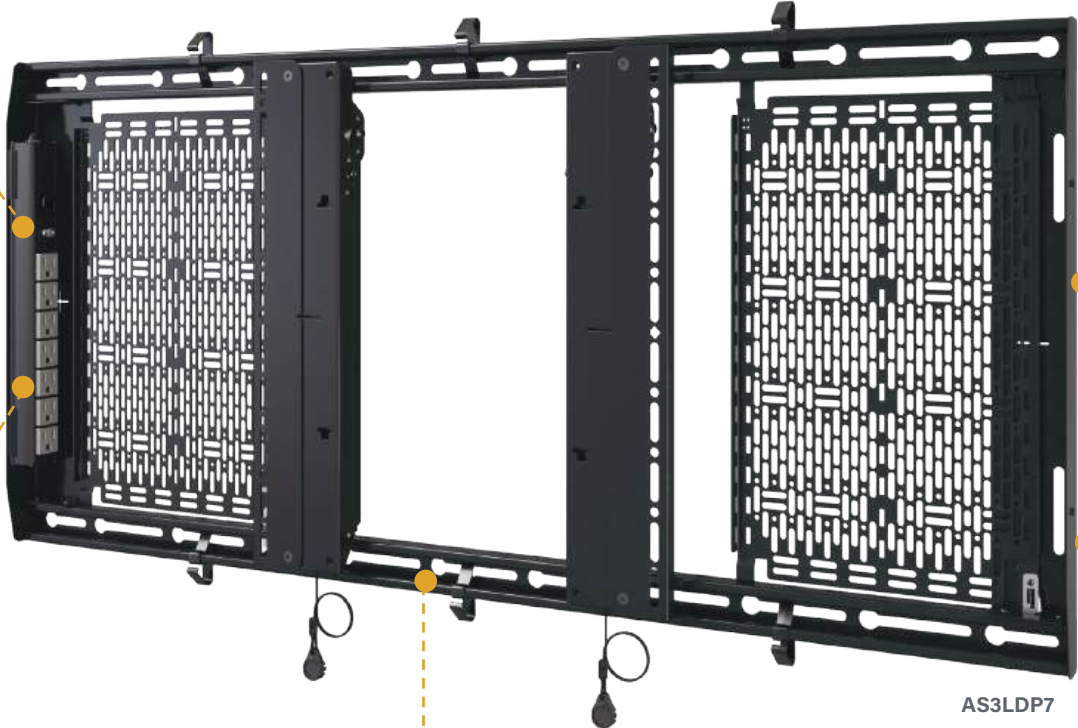

SLIM PROFILE of only 1.96" (50mm) Facilitates ADA compliance with displays less than 2" (51mm)

#10-32 tapped holes for PDU mounting clips

LATERAL SHIFT key-hole slots for continuous mounting positions

AS3LDP7

TEMPO™ PULL-OUT EXTENSION AND TILT

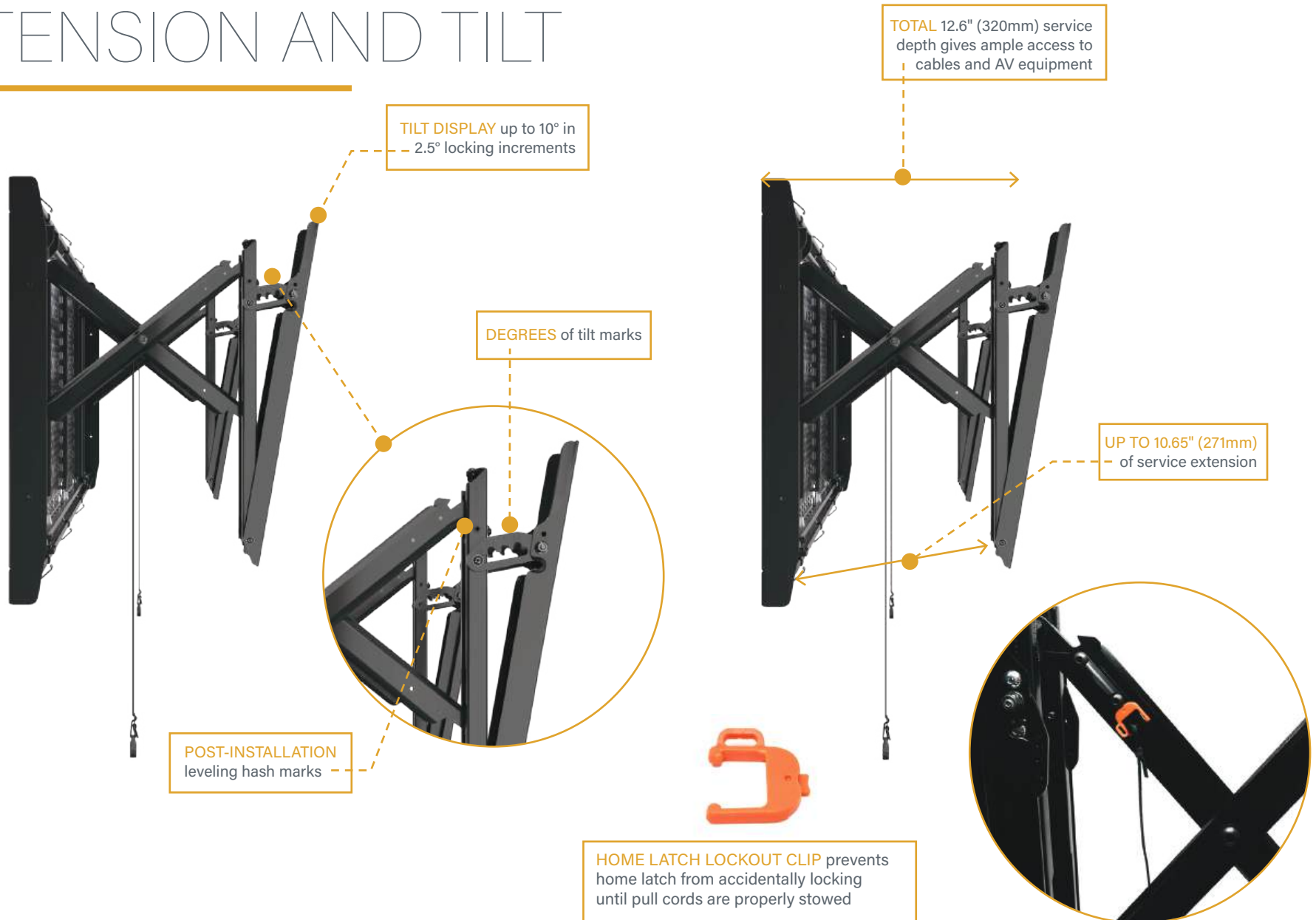

ACCESSORIES



CAMERA SHELF 1
AS3A100

- Cable Management Pass-Through Window
- 15 lbs (6.8 kg) Weight Capacity
- Vaddio® IntelliSHOT and ConferenceSHOT ePTZ Camera Bracket included



VIDEO SOUND BAR 2
AS3A101

- 20 lbs (9 kg) Weight Capacity when using interface bracket, 15 lbs (6.8 kg) when using "L" brackets
- Fits most video-sound bars with mounting holes in the back or bottom



60mm INTERFACE EXTENDER 3
FHB5174

- Increase vertical mounting from 450mm up to 650mm
- Interface brackets screw onto Tempo Wall Mount System without adding depth

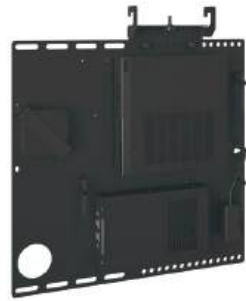

CRESTRON® UC BRACKET ACCESSORY 4
AS3A102

- Toolless thumb screws
- Lateral shift offers precision placement of the Crestron UC Bracket assembly behind display
- Crestron Flex Integrator Kit replaces Lever Lock plate storage area

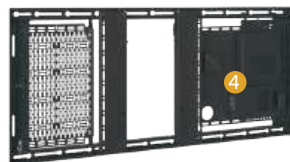

*Crestron Flex Integrator Kit not included



Camera Shelf and Sound Bar Mount can be mounted above or below display.

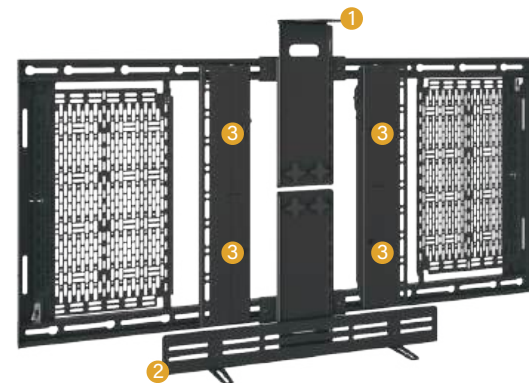

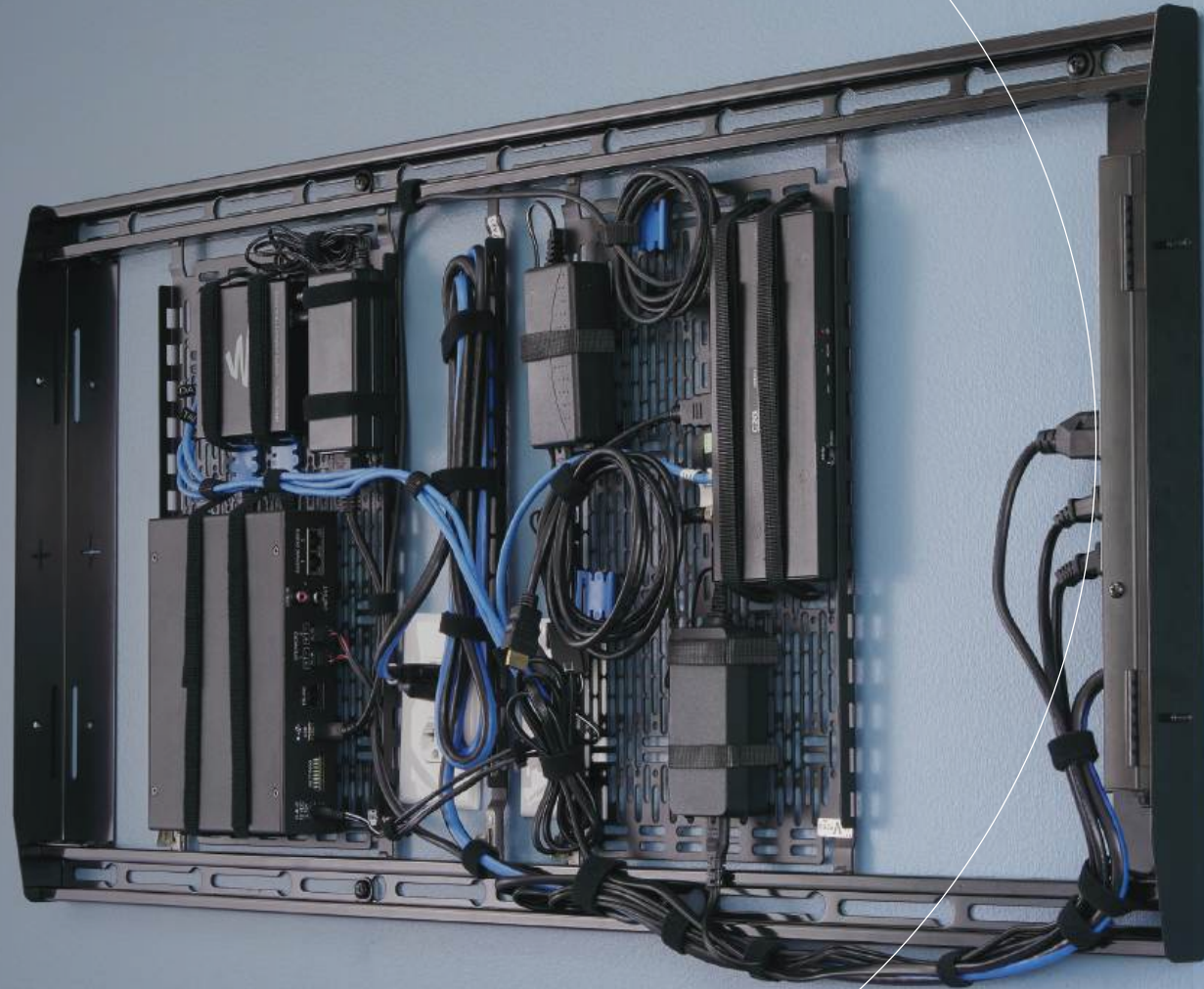

LEGRAND | AV COMMERCIAL BRANDS

C2G | Chief | Da-Lite | Luxul | Middle Atlantic | Vaddio | Wiremold

INSTALLER INSPIRED | legrandav.com

USA 866.977.3901 av.chief.support@legrand.com CANADA 877.345.4329 av.chief.canada@legrand.com

EMEA +31 495 580 840 av.emea.sales@legrand.com APAC +852 2145 4099 av.asia.sales@legrand.com

©2024 Legrand AV Inc. 230231 Rev C 10/24 Chief is a registered trademark of Legrand AV Inc. All other brand names or marks are used for identification purposes and are trademarks of their respective owners. All patents are protected under existing designations. Other patents pending.

FREESTYLE CHIEF-STYLE

The Freestyle Rotation Adapter enables an extremely wide variety of video wall configurations using either ConnexSys™ or Fusion® mounts. This versatile accessory provides infinite orientation possibilities, and the ability to overlap displays when combined with the FCADA Fusion depth accessory.

Use the information in this sheet to determine the best solution to support your unique configuration.

CONFIGURATION STYLE

For configurations requiring precision multi-display alignment, we recommend **ConnexSys Series**.

Examples:

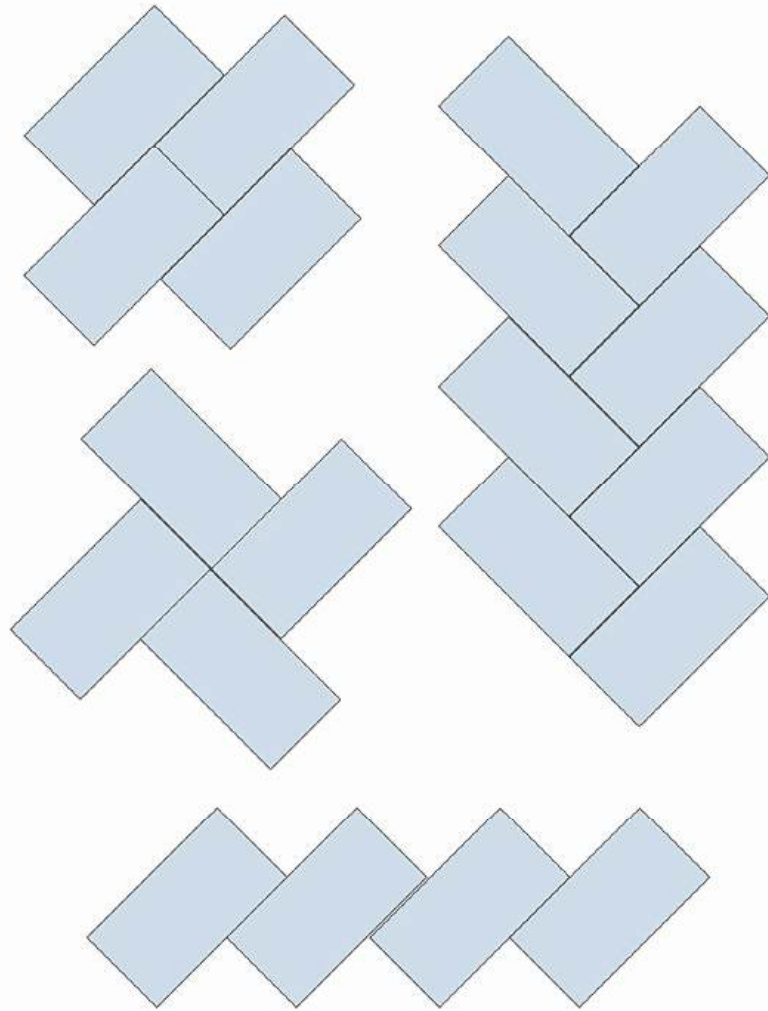

For configurations with overlapping displays, we recommend **Fusion Series single-stud mounts**.

Examples:

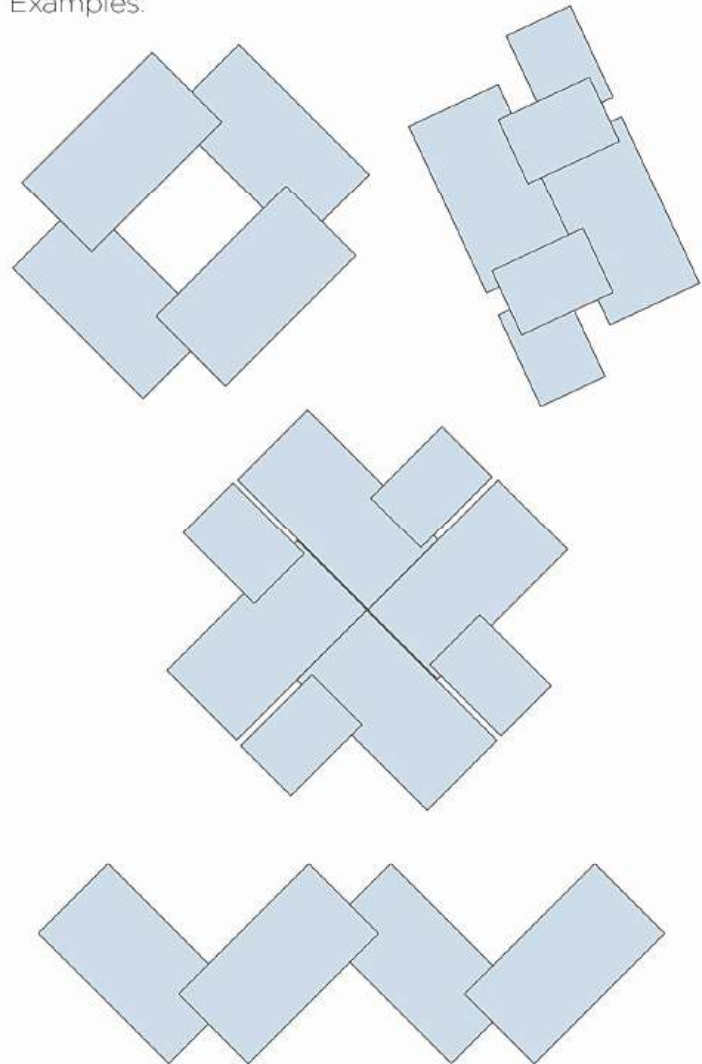

ConnexSys and Fusion Series mounts can be combined to accomplish an extensive range of freestyle configurations. For anything not listed here - including ceiling and cart/stand applications - please contact **APAC +852 2145 4099** av.asia.sales@legrand.com

DISPLAY COMPATIBILITY

MODEL	DESCRIPTION	TYPICAL DISPLAY SIZE	MINIMUM DISPLAY HEIGHT AT 45°	WEIGHT CAPACITY	MOUNTING PATTERN*
LVS1UP	ConnexSys Portrait Mount	55" +	27" (686 mm)	125 lbs (56.7 kg)	200 x 200; 200 x 300; 200 x 400; 300 x 300; 400 x 400
LVS1U	ConnexSys Landscape Mount	80" +	38.5" (978 mm)	125 lbs (56.7 kg)	
STMS1U	Fusion Single-Stud Mount	40" +	19" (483 mm)	55 lbs (24.9 kg)	
MTMS1U	Fusion Single-Stud Mount	40" +	19" (483 mm)	55 lbs (24.9 kg)	
MSM1U	Fusion Dual-Stud Mount	58" +	29" (737 mm)	105 lbs (47.6 kg)	
MODEL	DESCRIPTION	TYPICAL DISPLAY SIZE	MINIMUM DISPLAY HEIGHT IN PORTRAIT	WEIGHT CAPACITY	MOUNTING PATTERN*
MFAUB	Fusion Stand	50" +	24" (610 mm)	105 lbs (47.6 kg)	200 x 200; 200 x 300; 200 x 400; 300 x 300; 400 x 400
MPAUB	Fusion Cart	50" +	24" (610 mm)	105 lbs (47.6 kg)	

*Mounting pattern options are determined by the Freestyle Adapter (FRA).

MINIMUM DISPLAY HEIGHT

The minimum display height noted in the chart above is the smallest display size that will cover the widest dimension of the mount being used. The minimum display height will increase if the display is rotated to lesser/greater angles. For assistance calculating the minimum display height at a different angle of rotation, please contact our customer care team.

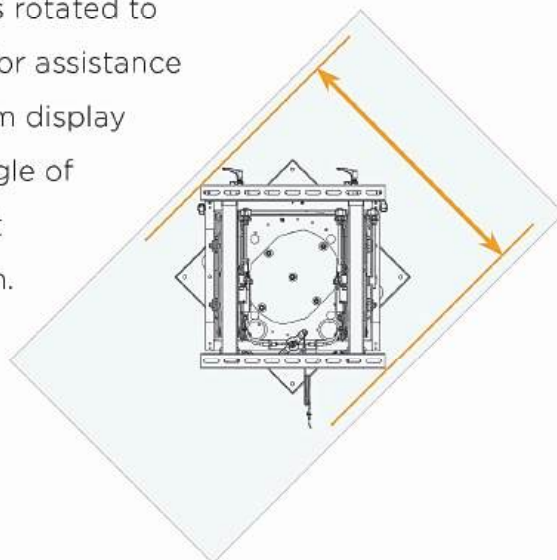

FEATURES

FRA - Freestyle Rotation Adapter

- Orientation: Infinite
- Rotation: 90° with positive lockouts at 15° increments
- Dimensions: 17.25 x 17.25 x 0.84" (438 x 438 x 21 mm)

FCADA - Fusion Depth Accessory

- Depth Adjustments: 3.25, 4 and 4.75" (83, 102 and 121 mm)
- Dimensions: 6.38 x 13.5 x 4.75" (162 x 343 x 121 mm)

Voyager

MOBILE CART

Move with Style



[Voyager™](#) is a compact mobile display solution to support flexible conferencing and collaboration in workspaces and digital signage. Built-in cable management and small device storage create quick and attractive AV installations. Sleek handles and a stylish woodgrain shelf promote accessibility and effortless movement.

Camera and speaker mounts integrate with a wide range of conferencing and collaboration technologies. The slim footprint of Voyager invites users to easily step up to interactive displays and move freely around the cart. Future proof conference rooms with an adaptable mobile cart compatible that accepts a wide range of displays.



High-quality, lockable casters ensure smooth movement, safety and stability



[PACL2 LeverLock™ storage plate](#) included for convenient mounting of small devices.



Lower storage area accommodates [PACL1 Lever Lock storage plate](#), sold separately

Displays can be mounted in landscape or portrait orientation. [Freestyle Flat Panel Rotation Adapter](#) accessory provides rotation from landscape to portrait orientation with rotating displays like MS Surface Hub and Samsung Flip 2.

FEATURES

- 175 lbs. weight capacity supports most touch displays up to 75" for interactivity
- Supports display mounting in portrait or landscape orientations.
- Robust display mounting with manual height adjustment, accommodates multiple heights and displays sizes
- Technology agnostic; providing peace of mind to future-proof your investment
- Ideal for corporate conferencing and collaboration, higher education collaboration spaces, digital signage for hospitality, and much more.
- Sophisticated design: elevated aesthetics to complement contemporary spaces
- Camera and speaker accessories integrate with a variety of popular conferencing and collaboration technologies
- Easily removable panels to conceal AV component storage for clean, attractive installation and cable management
- High-quality casters for easy, smooth movement with lockable rear casters
- Compact, low-profile footprint and sleek handles promote accessibility to technology and storage
- Installer inspired design for fast, intuitive assembly and installation
- Stocked globally for quick shipping
- Listed to UL 1678



WATCH THE VIDEO

SPECIFICATIONS

SKU	LSCU
CENTER OF DISPLAY TO FLOOR TABLE RANGE	50.72" – 60.96"
COLOR	Black or White
MANUAL HEIGHT ADJUSTMENT	10.2"
MOUNTING PATTERN COMPATIBILITY (UNIVERSAL VERSIONS)	200-200mm – 600x400mm
TILT	0°, 3° & 5° of back tilt (3 settings)
TYPICAL SCREEN SIZES	50" – 75"
WEIGHT CAPACITY	175 lbs.
ORIENTATION	Static install in landscape or portrait Dynamic rotation from landscape to portrait with FRA accessory, sold separately



VOYAGER MOBILE CART

ACCESSORIES



Voyager Storage Shelf Accessory

A stylish woodgrain shelf accessory for additional storage can be mounted with tool-free adjustment on the front or back of the Voyager Mobile Cart.

SKU	SCSS
COLOR	Black or White
FINISH	Wilsonart Veranda Teak HPL (8209)
DEPTH	10.5"
OVERALL DIMENSIONS (H X W X D)	4 x 30 x 10.5"
SHIPPING WEIGHT	11.3 lbs
WEIGHT CAPACITY	25 lbs



Voyager Video Conference Camera Shelf

Mount a variety of popular conferencing cameras above or below the display with the SCAC Video Conference Camera Shelf.

SKU	SCAC
COLOR	Black or White
DEPTH	8"
OVERALL DIMENSIONS (H X W X D)	12.5" x 8.5" x 8"
SHIPPING WEIGHT	5 lbs
TYPICAL SCREEN SIZES	50-75"
WEIGHT CAPACITY	10 lbs



Voyager Speaker Bar Accessory

Mount a variety of popular speaker and conferencing sound bars above or below the display with the SCAS Speaker Bar Accessory.

SKU	SCAS
COLOR	Black or White
DEPTH	2.75"
OVERALL DIMENSIONS (H X W X D)	22.5" x 7.75" x 2.75"
SHIPPING WEIGHT	5 lbs
TYPICAL SCREEN SIZES	50-75"
WEIGHT CAPACITY	15 lbs

TECH DRAWINGS

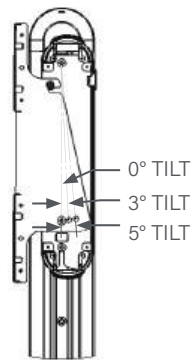
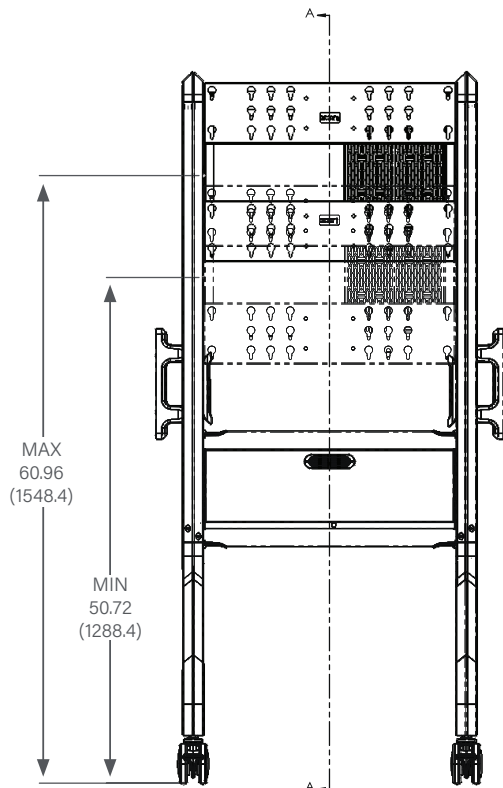
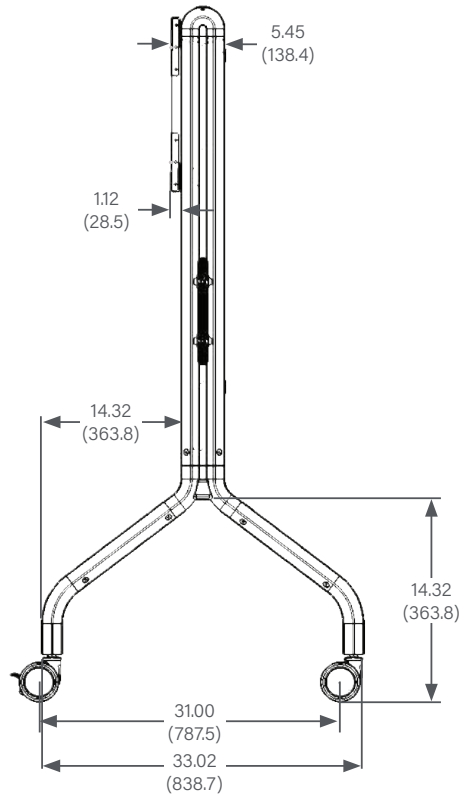
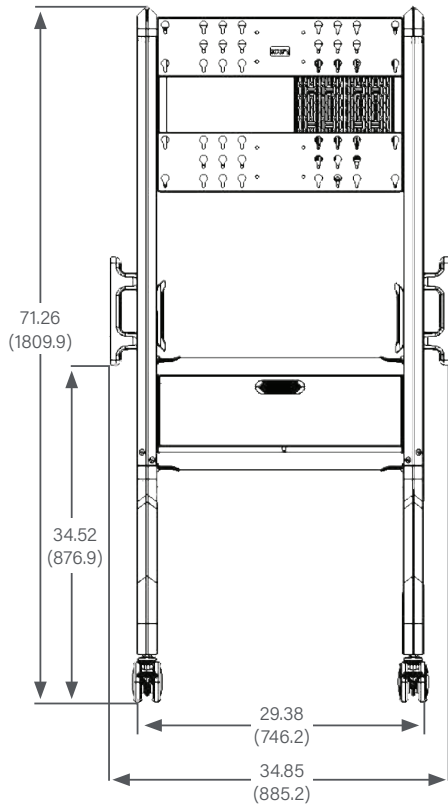

TECH DRAWINGS

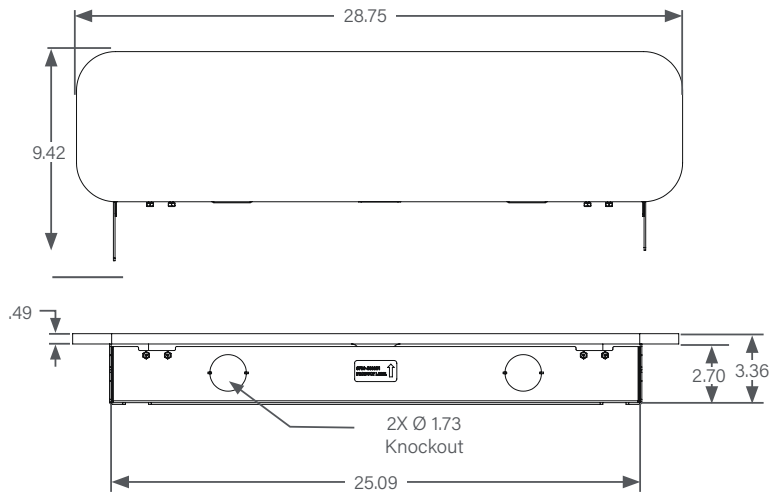

Voyager Storage Shelf Accessory

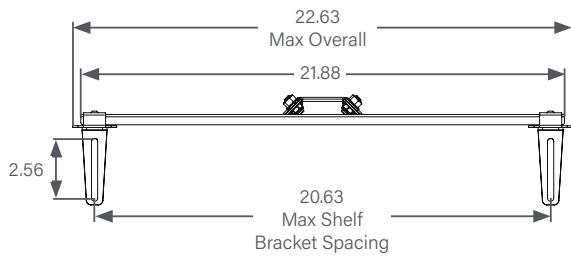
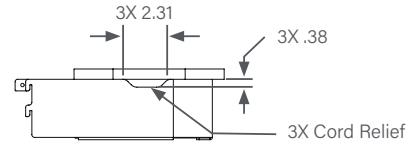

Voyager Speaker Bar Accessory

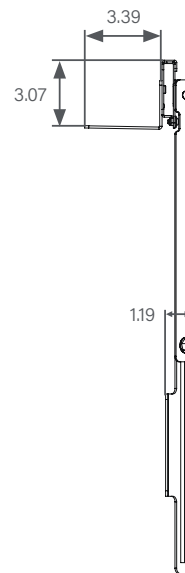
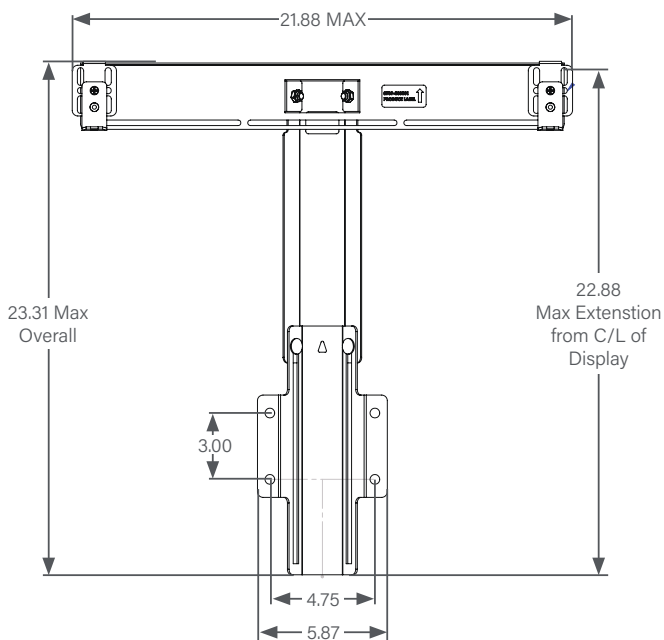

TECH DRAWINGS

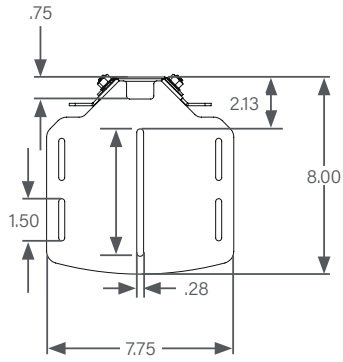

**Voyager Video Conference
Camera Shelf**

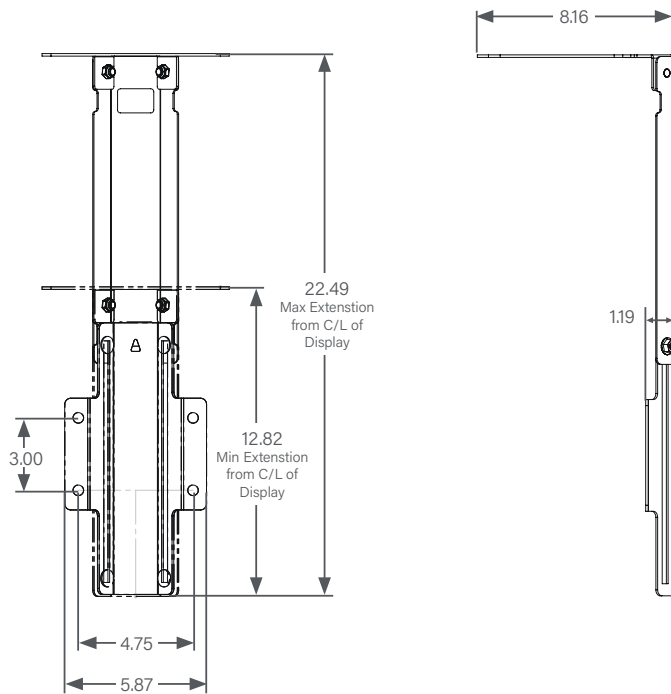

CHIEF[®]

A brand of **legrand**

LEGRAND | AV COMMERCIAL BRANDS

C2G | Chief | Da-Lite | Luxul | Middle Atlantic | Vaddio | Wiremold

INSTALLER INSPIRED | legrandav.com

USA 866.977.3901 av.chief.support@legrand.com CANADA 877.345.4329 av.chief.canada@legrand.com

EMEA +31 495 580 840 av.emea.sales@legrand.com APAC +852 2145 4099 av.asia.sales@legrand.com

©2024 Legrand AV Inc. 220567 Rev C 12/24 Chief is a registered trademark of Legrand AV Inc. All other brand names or marks are used for identification purposes and are trademarks of their respective owners. All patents are protected under existing designations. Other patents pending.



SERVICES VERSATECH OFFER

- Compatibility Checking and System Evaluation
 - Design Consultation
- Warranty Checking Courtesy of Fastronics